

L-BV 2 N Data sheet 2BV2 060 Liquid ring vacuum pump

IE3

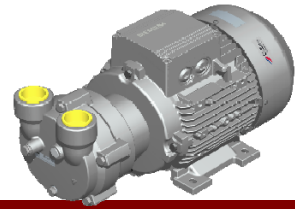

General information

Elmo Rietschle vacuum pumps of the model range L-BV2 are suitable for evacuating gases and wet vapours down to inlet pressures of 33 mbar abs. (97 % vacuum). All these vacuum pumps are equipped with built-in cavitation protection. They work cavitation free down to 80 mbar abs. For operation at lower inlet pressures the integrated cavitation protection should be connected for protecting the vacuum pump (no external pipes necessary).

The vacuum pumps are particularly space-saving, reliable and robust in their monoblock design. The reinforced stainless steel shaft, the permanently lubricated bearings and the ceramic internal coating of the pump housings prevent wear, corrosion and calcification.



Performance curves

Vacuum operation

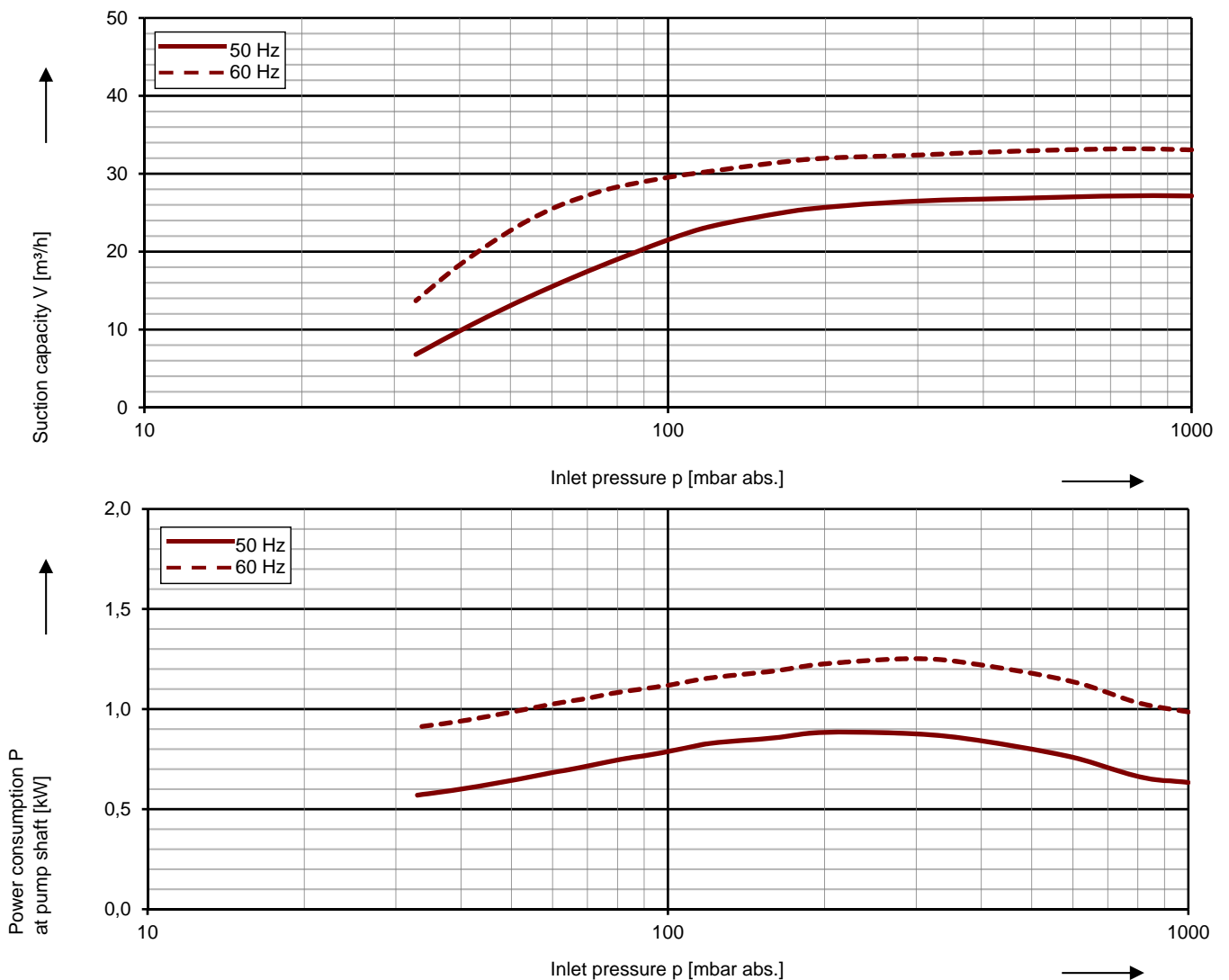

The characteristic curves are based on the evacuation of 100 % saturated air and an intake temperature of 20 °C. At a suction pressure of 1013 mbar abs. and a temperature of the operating liquid of 15 °C (water as operating liquid) the characteristic curves will be achieved. The tolerance is $\pm 10\%$.

The motors are supplied as standard for the input voltage ranges of 50 and 60 Hz and for the protection category IP55 as well as approved for UL and CSA. Vacuum ATEX-pumps with 2006/42 EG for category 2G are available, too.

Selection and ordering data

Typ 2BV2 060

Fre- quency	Rated			Service factor	Efficiency	Quantity of operating liquid 1)	Sound pressure level 2)	Weight Approx.	Order No.
	Voltage	Current	Power						
Hz	V	A	kW	SF	-	m ³ /h	dB(A)	kg	
3~ 50/60 Hz, IP55, Insulation material class F, UL (certificate number E489378)									
50	190-210 Δ	6,1 Δ	0,88	1,70	IE3	0,20	62	28 *	2BV2060-0 □ K02-1B
60	190-210 YY / 380-420 Y	7,0 YY / 3,5 Y	1,25	1,40	IE3	0,20	65		
	200 YY	6,0 YY	1,25	1,38	NP	0,20	65		
3~ 50/60 Hz, IP55, Insulation material class F, UL (certificate number E489378)									
50	220-240 Δ / 380-420 Y	5,3 Δ / 3,05 Y	0,88	1,70	IE3	0,20	62	28 *	2BV2060-0 □ K02-6B
60	220-240 YY / 440-480 Y	6,1 YY / 3,05 Y	1,25	1,40	IE3	0,20	65		
	230 YY / 460 Y	5,2 YY / 2,60 Y	1,25	1,38	NP	0,20	65		
3~ 50/60 Hz, IP55, Insulation material class F, UL (certificate number E489378)									
50	500 Y	2,35 Y	0,88	1,70	IE3	0,20	62	28 *	2BV2060-0 □ Q02-3B
60	575 Y	2,90 Y	1,25	1,38	NP	0,20	65		
3~ 50/60 Hz, IP55, Insulation material class F, UL (certificate number E489378)									
50	380-420 Δ / 660-725 Y	3,10 Δ / 1,80 Y	0,88	1,70	IE3	0,20	62	28 *	2BV2060-0 □ Q02-7B
60	440-480 Δ	3,05 Δ	1,25	1,40	IE3	0,20	65		
	460 Δ	2,60 Δ	1,25	1,38	NP	0,20	65		

Casing	Port plate	Impeller	Lantern
Cast iron (internal surface with ceramic coating)	Ceramic	Bronze	-

- 1) The quantities of operating liquid apply for fresh water operation without discharge liquid separator. Tolerance ±10%
- 2) Measuring surface sound pressure level acc. to EN ISO 3744, measured with an equivalent unit at a distance of 1 m. The pump is throttled to an average suction pressure, with piping connected, but no relief valves fitted, tolerance ±3 dB (A).

Voltage range		Efficiency	c us	Order No.	
50 Hz	60Hz			60 Hz	2BV2...-.. □ .. □
3~					
200 VΔ	200 V YY / 230 VΔ / 400 VY		•	K	1
190-210 VΔ	190-210 VYY / 220-240 VΔ / 380-420VY	IE3	•	K	6
200 V YY / 230 VΔ / 400 VY	230 V YY / 460 VY		•	K	6
190-210 VYY / 220-240 VΔ / 380-420VY	220-240 VYY / 440-480VY	IE3	•	K	6
475-525 V Y	550-600 V Y		•	Q	3
475-525 VΔ	550-600 VΔ		•	Q	5
400 VΔ / 690 V Y	460 VΔ		•	Q	7

All L-BV fulfil the 2006/42/EC (machinery) and 2006/95/EC (low voltage) directives and the EN 60034-1 norm "Rotating electrical machines". The motors comply with EN 60 034-1 / -2 / -30 (IEC 60034) and thermal class F. Voltage tolerances for three phase motors are +/-10%. The frequency tolerance is +/- 2 % maximum. Service factor (SF) and motor efficiency according NEMA MG1-12.

Operation liquid quantity for 50 Hz / 60 Hz [m³/h]

p1	Fresh water		Partial recirculation	
	15 °C	8 °C	10 °C	12 °C
mbar abs.	0,2 / 0,2	0,07 / 0,09	0,09 / 0,1	0,11 / 0,13
> 500	0,2 / 0,2	0,07 / 0,09	0,09 / 0,1	0,11 / 0,13
200 - 500	0,2 / 0,2	0,07 / 0,09	0,09 / 0,1	0,11 / 0,13
< 200	0,2 / 0,2	0,07 / 0,09	0,09 / 0,1	0,11 / 0,13

For partial recirculation operation the quantity of the fresh applied refrigerant can be reduced by circulation of the operating liquid in a circuit (with discharge liquid separator and internal recirculation of the operating liquid, available as accessories). Complete circuit systems L-SV available on request.

Max. additional water carry over / Back pressure

Frequency [Hz]	Water carry-over [m ³ /h]	Back pressure [mbar] atm.
50	0,5	1200
60	0,5	1200

An inlet pressure of 10 mbar abs. can be achieved by connecting a gas ejector (see accessories). The gas ejector can be mounted directly onto the vacuum pump.

The cast iron machines are completely painted in standard color RAL 9006.

All cast parts of the stainless steel version are pickled and passivated, the motor is standardly painted in RAL 9006.

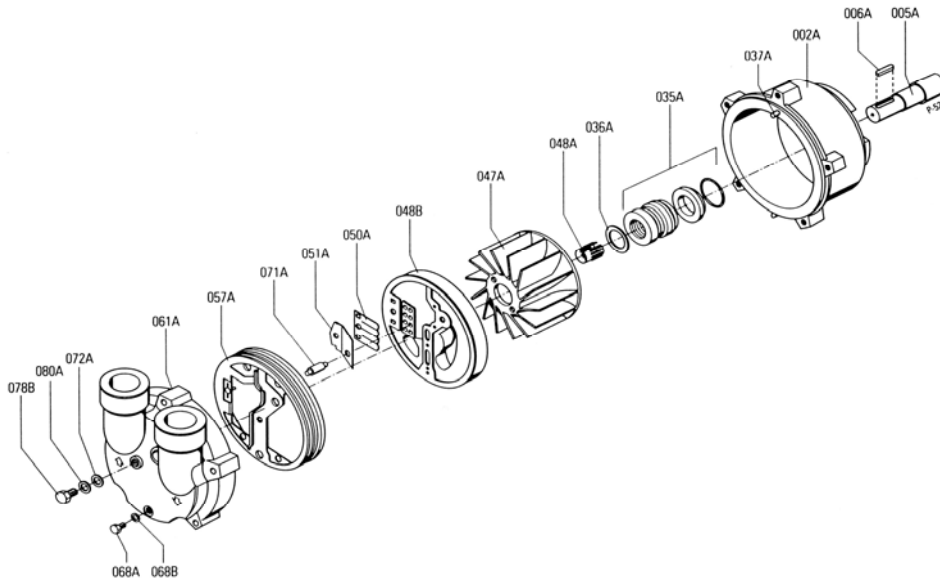

Part No.		Materials			
		Cast iron / ceramic / bronze	CrNi steel / ceramic / CrNi steel	CrNi steel / ceramic / CrNi steel	CrNi steel / CrNi steel / CrNi steel
002	Casing	Cast iron - internal surface with ceramic coating against corrosion and abrasion EN-GJL HB 195 / EN-JL2030 EN 1561	Cast chrome-nickel-molybdenum steel (G-X6CrNiMo 18-10 / 1.4408) EN 10213-4	Cast chrome-nickel-molybdenum steel (G-X6CrNiMo 18-10 / 1.4408) EN 10213-4	Cast chrome-nickel-molybdenum steel (G-X6CrNiMo 18-10 / 1.4408) EN 10213-4
005	Pump shaft	Chrome steel (X20Cr13 / 1.4021) EN 10088 - 3	Chrome steel (X20Cr13 / 1.4021) EN 10088 - 3	Chrome-nickel-molybdenum steel (X6CrNiMoTi 17-12-2 / 1.4571) EN 10088 - 3	Chrome-nickel-molybdenum steel (X6CrNiMoTi 17-12-2 / 1.4571) EN 10088 - 3
006	Feather key	Chrome-nickel-molybdenum steel (X6CrNiMoTi 17-12-2 / 1.4571) EN 10088 - 3	Chrome-nickel-molybdenum steel (X6CrNiMoTi 17-12-2 / 1.4571) EN 10088 - 3	Chrome-nickel-molybdenum steel (X6CrNiMoTi 17-12-2 / 1.4571) EN 10088 - 3	Chrome-nickel-molybdenum steel (X6CrNiMoTi 17-12-2 / 1.4571) EN 10088 - 3
035	Mechanical seal	Carbon / Ceramic / Viton (FPM) / Chrome-nickel steel (EN 12756 - BVVGG)	Carbon / Ceramic / Viton (FPM) / Chrome-nickel steel (EN 12756 - BVVGG)	SIC / Carbon / Viton (FPM) / Teflon (PTFE) sheathed / Chrome-nickel-molybdenum steel (EN 12756 - Q1BM1GG)	SIC / Carbon / Viton (FPM) / Teflon (PTFE) sheathed / Chrome-nickel-molybdenum steel (EN 12756 - Q1BM1GG)
036	Washer	Chrome-nickel steel X10CrNiS 18-9 / 1.4305 / EN 10088 - 3	Chrome-nickel steel X10CrNiS 18-9 / 1.4305 / EN 10088 - 3	Chrome-nickel steel X10CrNiS 18-9 / 1.4305 / EN 10088 - 3	Chrome-nickel steel X10CrNiS 18-9 / 1.4305 / EN 10088 - 3
037	Set screw	Chrome-nickel-molybdenum steel (X5CrNiMo 17-12-2 / 1.4401) EN 10088 - 2	Chrome-nickel-molybdenum steel (X5CrNiMo 17-12-2 / 1.4401) EN 10088 - 2	Chrome-nickel-molybdenum steel (X5CrNiMo 17-12-2 / 1.4401) EN 10088 - 2	not applicable
047	Impeller	Cast aluminium bronze (G-CuAl10Fe5Ni5 / CC33G-GS) EN 1982	Cast chrome-nickel-molybdenum steel (G-X6CrNiMo 18-10 / 1.4408) EN 10213-4	Cast chrome-nickel-molybdenum steel (G-X6CrNiMo 18-10 / 1.4408) EN 10213-4	Cast chrome-nickel-molybdenum steel (G-X6CrNiMo 18-10 / 1.4408) EN 10284
048	Tolerance ring for impeller	Chrome-nickel steel (X12CrNi 17-7 / 1.4310) EN 10088 - 2	Chrome-nickel steel (X12CrNi 17-7 / 1.4310) EN 10088 - 2	Chrome-nickel steel (X12CrNi 17-7 / 1.4310) EN 10088 - 2	Chrome-nickel steel (X12CrNi 17-7 / 1.4310) EN 10088 - 2
049	Port plate	Ceramic - C221 EN 60672 - 1	Ceramic - C221 EN 60672 - 1	Ceramic - C221 EN 60672 - 1	Cast chrome-nickel-molybdenum steel (G-X6CrNiMo 18-10 / 1.44.08) EN 10213-4
050	Valve plate	Teflon (PTFE)	Teflon (PTFE)	Teflon (PTFE)	Teflon (PTFE)
051	Intercepting plate	Chrome-nickel-molybdenum steel (X10CrNiMoTi 18-10 / 1.4571) EN 10088 - 2	Chrome-nickel-molybdenum steel (X10CrNiMoTi 18-10 / 1.4571) EN 10088 - 2	Chrome-nickel-molybdenum steel (X10CrNiMoTi 18-10 / 1.4571) EN 10088 - 2	Chrome-nickel-molybdenum steel (X10CrNiMoTi 18-10 / 1.4571) EN 10088 - 2
057	Gasket for cover	Nitrile-butadiene-caotchouc (NBR) ISO 1629	Viton (FPM)	Viton (FPM)	flat gasket: Teflon (PTFE) and O-ring: silicone-caotchouc / Teflon (PTFE) sheathed
061	Cover	Cast iron (EN-GJL HB 195 / EN-JL2030) EN1561	Cast chrome-nickel-molybdenum steel (G-X6CrNiMo 18-10 / 1.4408) EN 10213-4	Cast chrome-nickel-molybdenum steel (G-X6CrNiMo 18-10 / 1.4408) EN 10213-4	Cast chrome-nickel-molybdenum steel (G-X6CrNiMo 18-10 / 1.4408) EN 10213-4
063	Screw	Steel (DIN ISO 8992)	Steel (DIN ISO 8992)	Steel (DIN ISO 8992)	Steel (DIN ISO 8992)
068	Plug screw	Machining steel, lead alloyed (11SMnPb30 / 1.0718) EN 10087	Chrome-nickel-molybdenum steel (X10CrNiMoTi 18-10 / 1.4571) EN 10088 - 3	Chrome-nickel-molybdenum steel (X10CrNiMoTi 18-10 / 1.4571) EN 10088 - 3	Chrome-nickel-molybdenum steel (X10CrNiMoTi 18-10 / 1.4571) EN 10088 - 3
069	Sealing ring	Teflon (PTFE)	Teflon (PTFE)	Teflon (PTFE)	Teflon (PTFE)
070	O-Ring	FPM (flour rubber)	FPM (flour rubber)	FPM (flour rubber)	FEP (Perfluorethylenpropylen) & Silicon
071	Pipe of cavitation protection	Chrome-nickel-molybdenum steel (X10CrNiMoTi 18-10 / 1.4571) EN 10088 - 3	Chrome-nickel-molybdenum steel (X10CrNiMoTi 18-10 / 1.4571) EN 10088 - 3	Chrome-nickel-molybdenum steel (X10CrNiMoTi 18-10 / 1.4571) EN 10088 - 3	Chrome-nickel-molybdenum steel (X10CrNiMoTi 18-10 / 1.4571) EN 10088 - 3
072	Washer for cavitation protection	Chrome-nickel steel (X5CrNi 18-10 / 1.4301) EN 10088 - 3	Chrome-nickel steel (X5CrNi 18-10 / 1.4301) EN 10088 - 3	Chrome-nickel steel (X5CrNi 18-10 / 1.4301) EN 10088 - 3	Chrome-nickel steel (X5CrNi 18-10 / 1.4301) EN 10088 - 3
079	Plug screw	Machining steel, lead alloyed (11SMnPb30 / 1.0718) EN 10087	Chrome-nickel-molybdenum steel (X5CrNiMo 17-12-2 / 1.4401) EN 10088 - 3	Chrome-nickel-molybdenum steel (X5CrNiMo 17-12-2 / 1.4401) EN 10088 - 3	Chrome-nickel-molybdenum steel (X5CrNiMo 17-12-2 / 1.4401) EN 10088 - 3
080	Sealing ring	Teflon (PTFE)	Teflon (PTFE)	Teflon (PTFE)	Teflon (PTFE)

Changes in particular of the quoted performance curve, data and weights may occur without prior notice. The data given do not constitute an obligation from our side to deliver as shown.