

L-BV 7 N Data sheet 2BV7 061 Liquid ring vacuum pump

IE3



General information

Elmo Rietschle vacuum pumps of the model range L-BV7 are suitable for evacuating gases and wet vapours down to inlet pressures of 33 mbar abs. (97 % vacuum). All these vacuum pumps are equipped with built-in cavitation protection. They work cavitation free down to 80 mbar abs. For operation at lower inlet pressures the integrated cavitation protection should be connected for protecting the vacuum pump (no external pipes necessary).

Our pumps have stainless steel shafts which makes them corrosion resistant. They work safely and reliably even under extreme conditions, like those in humid processes.



Performance curves

Vacuum operation

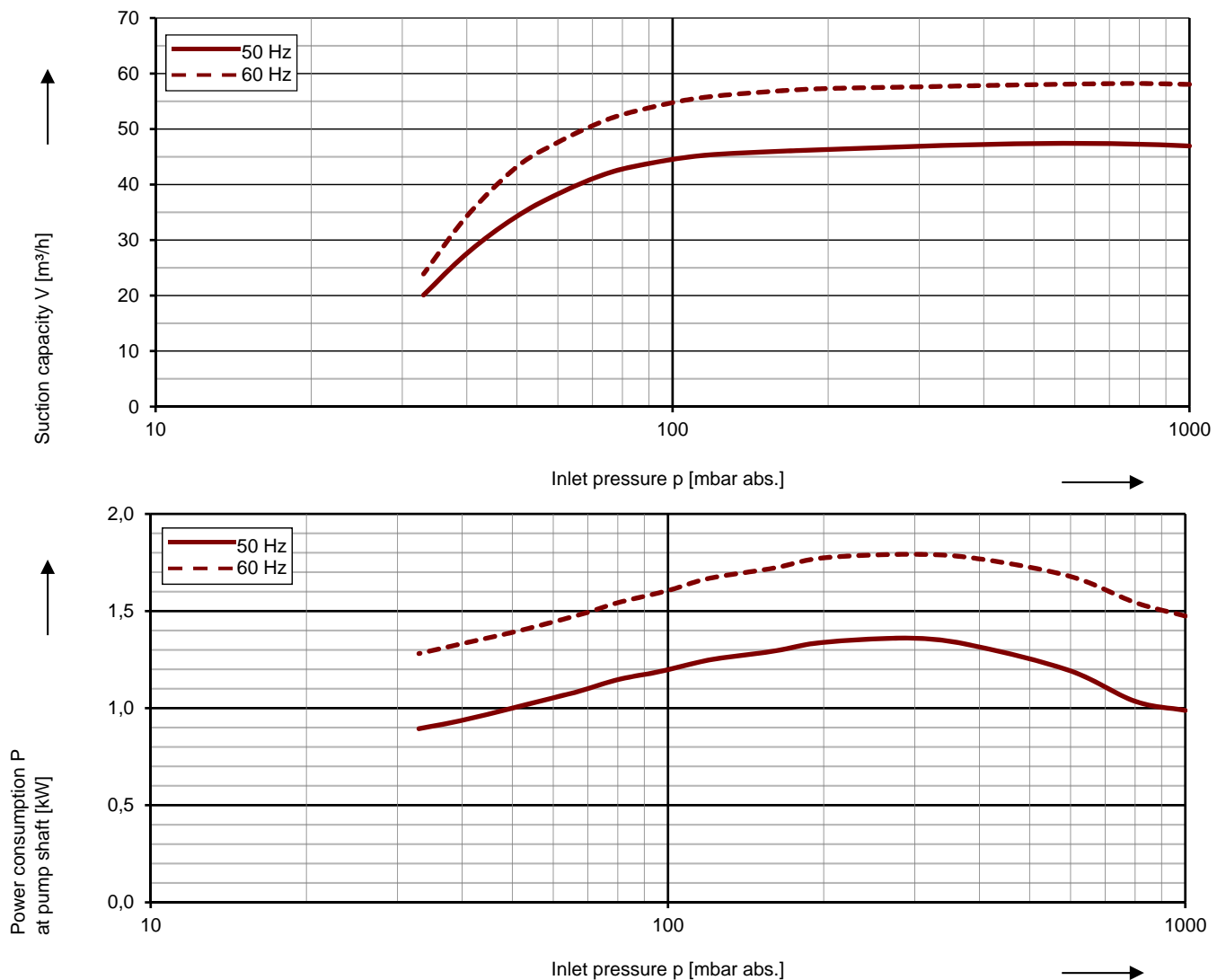

The characteristic curves are based on the evacuation of 100 % saturated air and an intake temperature of 20 °C. At a suction pressure of 1013 mbar abs. and a temperature of the operating liquid of 15 °C (water as operating liquid) the characteristic curves will be achieved. The tolerance is $\pm 10\%$.

The motors are supplied as standard for the input voltage ranges of 50 and 60 Hz and for the protection category IP55 as well as approved for UL and CSA.

Selection and ordering data

Typ 2BV7 061

Fre- quency	Rated			Service factor	Efficiency	Quantity of operating liquid 1)	Sound pressure level 2)	Weight Approx.	Order No.
	Voltage	Current	Power						
Hz	V	A	kW	SF	-	m ³ /h	dB(A)	kg	
3~ 50/60 Hz, IP55, Insulation material class F, UL (certificate number E489378)									
50	190-210 Δ	8,7 Δ	1,4	1,57	IE3	0,09	65	30	2BV7061-1 □ K00-1B
60	190-210 YY / 380-420 Y	10,0 YY / 5,0 Y	1,8	1,42	IE3	0,09	71		
	200 YY	8,4 YY	1,8	1,41	NP	0,09	71		
3~ 50/60 Hz, IP55, Insulation material class F, UL (certificate number E489378)									
50	220-240 Δ / 380-420 Y	7,5 Δ / 4,35 Y	1,4	1,57	IE3	0,09	65	30	2BV7061-1 □ K00-6B
60	220-240 YY / 440-480 Y	8,6 YY / 4,3 Y	1,8	1,42	IE3	0,09	71		
	230 YY / 460 Y	7,3 YY / 3,65 Y	1,8	1,41	NP	0,09	71		
3~ 50/60 Hz, IP55, Insulation material class F, UL (certificate number E489378)									
50	500 Y	3,35 Y	1,4	1,57	IE3	0,09	65	30	2BV7061-1 □ Q00-3B
60	575 Y	2,90 Y	1,8	1,41	NP	0,09	71		
3~ 50/60 Hz, IP55, Insulation material class F, UL (certificate number E489378)									
50	380-420 Δ / 660-725 Y	4,35 Δ / 2,50 Y	1,4	1,57	IE3	0,09	65	30	2BV7061-1 □ Q00-7B
60	440-480 Δ	4,30 Δ	1,8	1,42	IE3	0,09	71		
	460 Δ	3,65 Δ	1,8	1,41	NP	0,09	71		

Materials			
Casing	Port plate	Impeller	Lantern
CrNi steel	CrNi steel	Bronze	Cast iron

- 1) The quantities of operating liquid apply for fresh water operation without discharge liquid separator.
- 2) Measuring surface sound pressure level acc. to EN ISO 3744, measured with an equivalent unit at a distance of 1 m. The pump is throttled to an average suction pressure, with piping connected, but no relief valves fitted, tolerance ±3 dB (A).

Voltage range		Efficiency	c _{RU} ^{us}	Order No.	
50 Hz	60 Hz			60 Hz	2BV7....- □ ..- □
3~					
200 VΔ	200 V YY / 230 VΔ / 400 VY	NEMA Premium IE3	•	K	1
190-210 VΔ	190-210 VYY / 220-240 VΔ / 380-420VY				
200 V YY / 230 VΔ / 400 VY	230 V YY / 460 VY	NEMA Premium IE3	•	K	6
190-210 VYY / 220-240 VΔ / 380-420VY	220-240 VYY / 440-480VY				
475-525 V Y	550-600 V Y	NEMA Premium	•	Q	3
475-525 VΔ	550-600 VΔ				
400 VΔ / 690 V Y	460 VΔ				

All L-BV fulfil the 2006/42/EC (machinery) and 2006/95/EC (low voltage) directives and the EN 60034-1 norm "Rotating electrical machines". The motors comply with EN 60 034-1 / -2 / -30 (IEC 60034) and thermal class F. Voltage tolerances for three phase motors are +/-10%. The frequency tolerance is +/- 2 % maximum. Service factor (SF) and motor efficiency according NEMA MG1-12.

Operation liquid quantity for 50 Hz / 60 Hz [m³/h]

p1 mbar abs.	Fresh water		Partial recirculation		
	15 °C	8 °C	10 °C	12 °C	
> 500	0,1 / 0,1	0,06 / 0,07	0,07 / 0,08	0,08 / 0,08	
200 - 500	0,12 / 0,12	0,07 / 0,08	0,08 / 0,09	0,09 / 0,1	
< 200	0,23 / 0,23	0,1 / 0,11	0,12 / 0,13	0,14 / 0,16	

For partial recirculation operation the quantity of the fresh applied refrigerant can be reduced by circulation of the operating liquid in a circuit (with discharge liquid separator and internal recirculation of the operating liquid, available as accessories). Complete circuit systems L-SV available on request.

Max. additional water carry over / Back pressure

Frequency [Hz]	Water carry-over [m ³ /h]	Back pressure [mbar] atm.
50	0,575	1300
60	0,575	1300

An inlet pressure of 10 mbar abs. can be achieved by connecting a gas ejector (see accessories). The gas ejector can be mounted directly onto the vacuum pump.

The cast iron machines are completely painted in standard color RAL 9006.

All cast parts of the stainless steel version are pickled and passivated, the motor is standardly painted in RAL 9006.

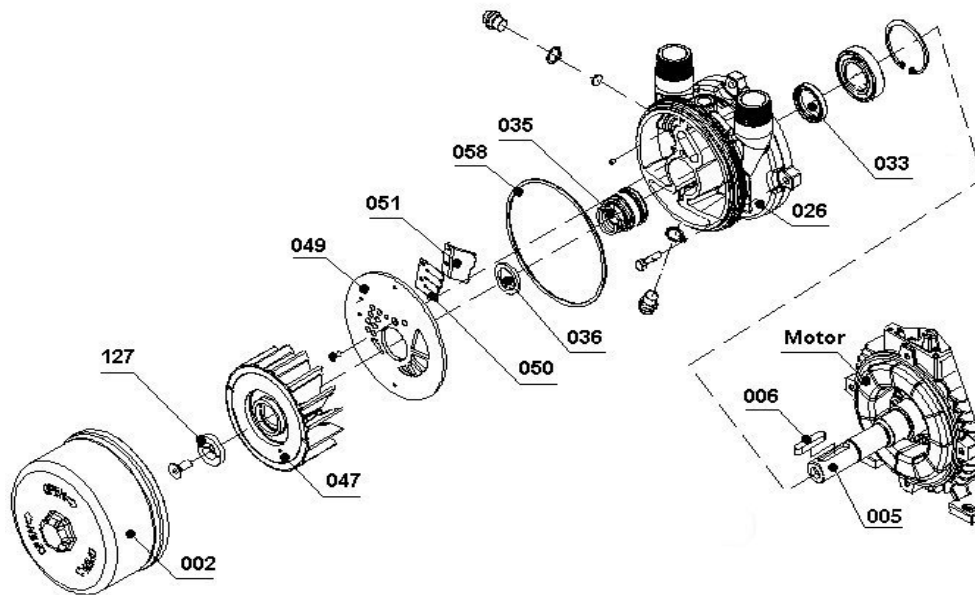

Part No.		Materials
		CrNi steel / bronze / cast iron
002	Casing	Chrome-nickel steel (X5CrNi 1810 - / 1.4301) EN 10088 - 2
005	Pump shaft	Chrome-steel (X20Cr13 / 1.4021) EN 10088 - 3
006	Feather key	Chrome-nickel-molybdenum steel (X6CrNiMoTi 17-12-2 / 1.4571) EN 10088 - 3
026	Lantern	Grey cast iron (EN-GJL200 / EN-JL 2030) EN 1561
033	Radial shaft seal	Nitrile-butadiene-caotchouc (NBR) ISO 1629
035	Mechanical seal	SIC / Carbon / Viton (FPM) / chrome-nickel-molybdenum steel (EN 12756 - BQ1VGG)
036	Washer	Chrome-nickel-molybdenum steel (X5CrNiMo 17-12-2 / 1.4401) EN 10088 - 3
047	Impeller	Cast aluminium bronze (G-CuAl10Fe5Ni5 / CC33G-GS) EN 1982
049	Port plate	Chrome-nickel-molybdenum steel (X6CrNiTi 18-10 / 1.4541) EN 10088 - 2
050	Valve plate	Teflon(PTFE)
051	Intercepting plate	Chrome-nickel-molybdenum steel (X5CrNiMo 17-12-2 / 1.4401) EN 10088 - 2
058	Seal (O-Ring)	Nitrile-butadiene-caotchouc (NBR) ISO 1629
127	Retaining washer	Chrome-nickel-molybdenum steel (X6CrNiMoTi 17-12-2 / 1.4571) EN 10088 - 2